

Customer: ISPAG  
 Ref. order: KST300/125500  
 Ref. offer: --  
 Ref. OFV: OFV26-0484

## N° 2 Pcs

Tank1: DHW  
 Material: Inox AISI 316L (1.4404)  
 External treat.: PICKLED  
 Internal treat.: PICKLED  
 Pressure (exerc./test): 6/12 bar

Insulation: NOT INSULATED

Bill of Materials: 99.03301453-26N							
ID	Description	Code	Notes	Material	UM	Qt	Cut (mm)
1	1/2" L=100	TML000864		Inox AISI 316L (1.4404)	PZ	4	--
2	1" L=20	TML000720		Inox AISI 316L (1.4404)	PZ	1	--
3	2" L=100	TML001095		Inox AISI 316L (1.4404)	PZ	5	--
4	120/180 BLIND	TML002195		Inox AISI 316L (1.4404)	PZ	1	--
5	210/280 BLIND	TML005497		Inox AISI 316L (1.4404)	PZ	1	--
6	120/180 GASKET	TML005559		Sesalit Eco	PZ	1	--
7	210/280 GASKET	TML005557		Sesalit Eco	PZ	1	--
8	120/180 FLANGE	TML001535		Inox AISI 316L (1.4404)	PZ	1	--
9	210/280 FLANGE M14	TML001537		Inox AISI 316L (1.4404)	PZ	1	--
10	D.1100 FOOT	TML005285		Inox AISI 304 (1.4307)	PZ	3	--
11	LIFTING POINT	TML005372		Inox AISI 304 (1.4307)	PZ	2	--
12	DN25 PIPE	TML012149		Inox AISI 316L (1.4404)	MT	0.02	1 x 20
13	DN25 PIPE	TML012790		Inox AISI 316L (1.4404)	MT	0.682	1 x 682
14	DN50 SPARGE PIPE	TML003646		Inox AISI 316L (1.4404)	MT	1.6	4 x 400
15	ROD Ø8	TML005341		Inox AISI 304 (1.4307)	MT	0.1	1 x 100

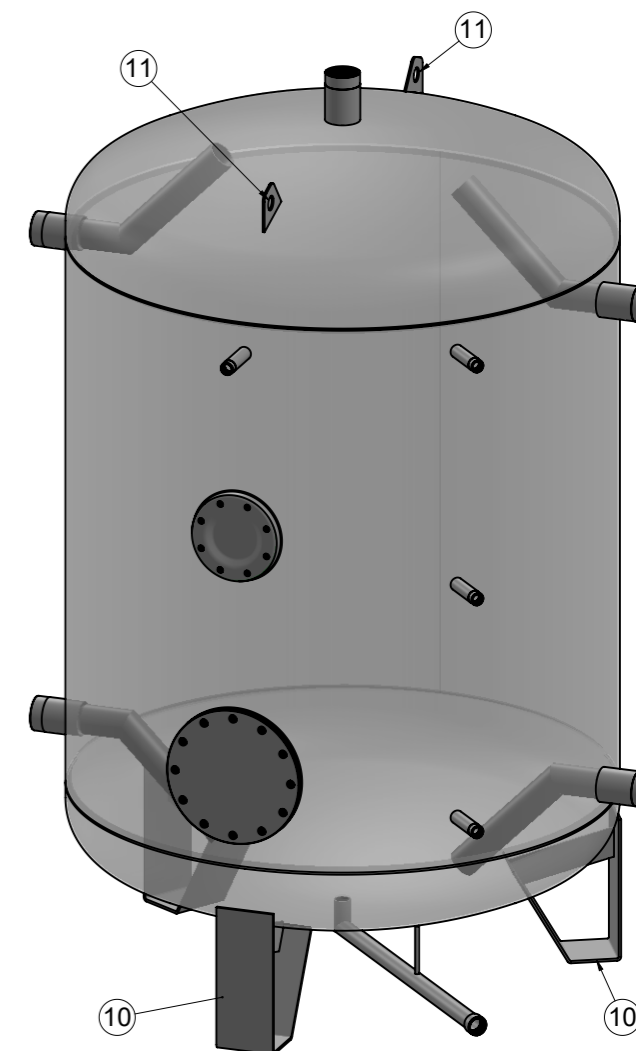
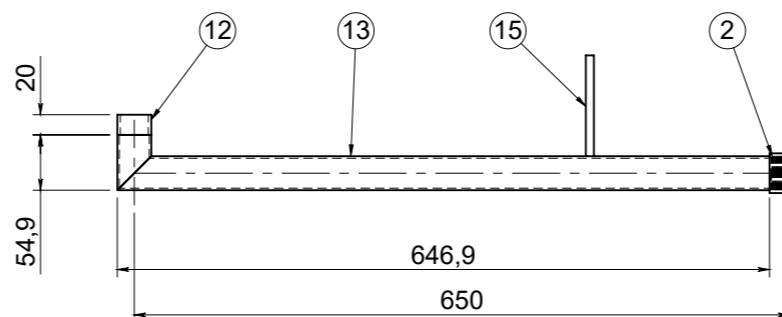
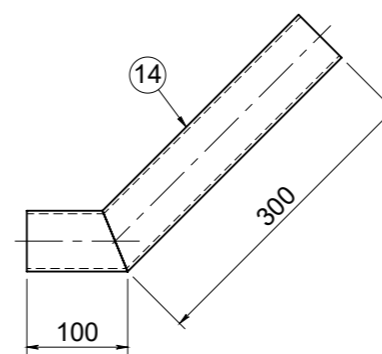

PER CLIENTE

TOLLERANZA QUOTE ± 5MM Dimensions Tolerance ± 5mm	Nome file: TML016712	Nr. Articolo:	
	Stato: In Approv.ne Comm.le	<b>99.03301453-26N</b>	
	Data: 30/03/2026	ATX SPECIALE 1500 Lt NUDO	
	Autore: Giuliano Iodice		
	Pag: 1 di 1	Scala: 1:15	<b>Foglio1</b>
Formato: A3		Material:	Peso:
		Trattamento:	<b>241.29 kg</b>
		Rev: 00_c - Crea: -- -- Approvata: GI 30/03/2026	
		EMISSIONE PER ACCETTAZIONE	