

ID	Description	Code	Notes	Material	UM	Qt	Cut (mm)
1	1/2" L=100	TML000864		Inox AISI 316L (1.4404)	PZ	5	--
2	1" L=20	TML000720		Inox AISI 316L (1.4404)	PZ	1	--
3	2" L=100	TML001095		Inox AISI 316L (1.4404)	PZ	6	--
4	400/480 FLANGE	TML005528		Inox AISI 304 (1.4307)	PZ	1	--
5	400/480 BLIND	TML005491		Inox AISI 316L (1.4404)	PZ	1	--
6	400/480 COLLAR	TML004950		Inox AISI 316L (1.4404)	PZ	1	--
7	400/480 GASKET	TML005552		Sesalit Eco	PZ	1	--
8	EXCH. 8 M <sup>2</sup> W/2 CONN. 1"1/4	TML016711		Inox AISI 316L (1.4404)	PZ	1	--
9	D.1200 FOOT	TML005286		Inox AISI 304 (1.4307)	PZ	3	--
10	LIFTING POINT	TML005372		Inox AISI 304 (1.4307)	PZ	2	--
11	DN25 PIPE	TML012149		Inox AISI 316L (1.4404)	MT	0.02	1 x 20
12	DN25 PIPE	TML012790		Inox AISI 316L (1.4404)	MT	0.682	1 x 682
13	DN50 SPARGE PIPE	TML003646		Inox AISI 316L (1.4404)	MT	1.2	3 x 400
14	ROD Ø8	TML005341		Inox AISI 304 (1.4307)	MT	0.15	1 x 150

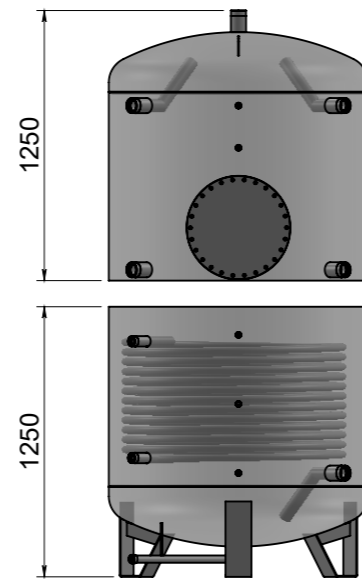
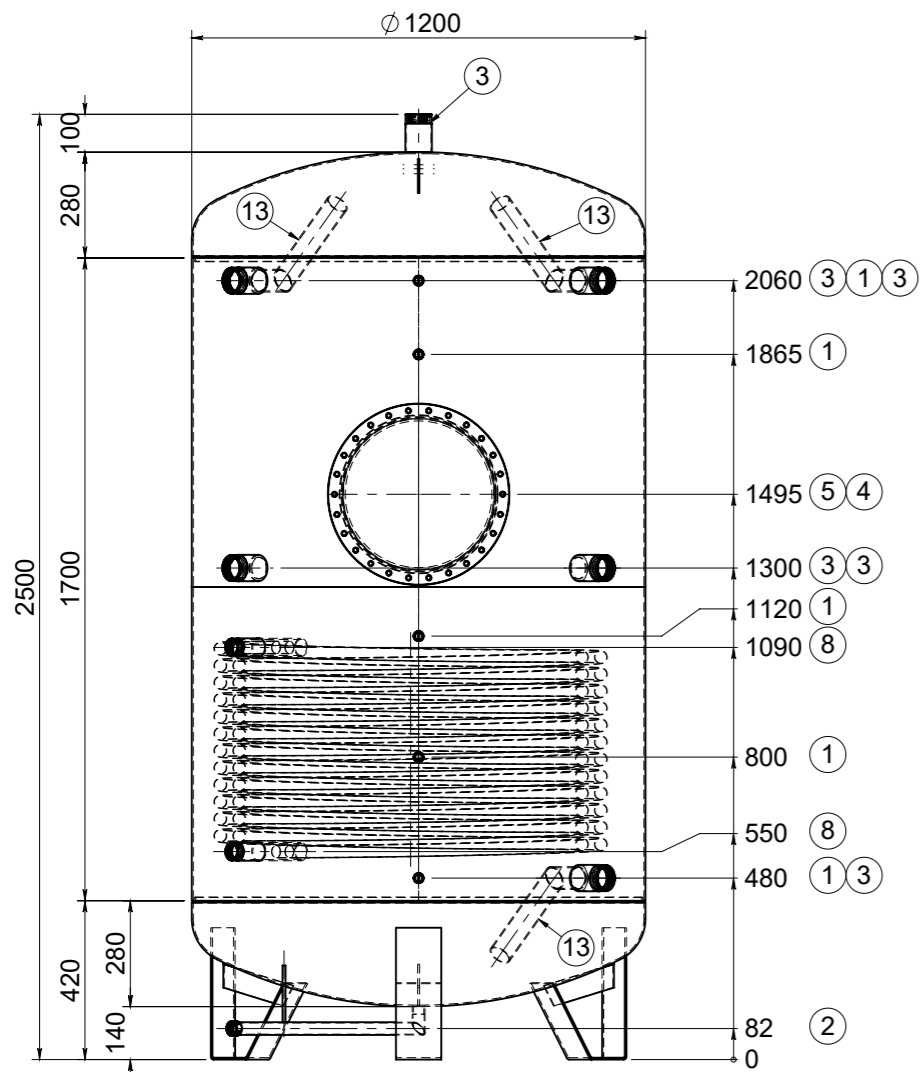

Customer: ISPAG  
 Ref. order: KST300-125423  
 Ref. offer: --  
 Ref. OFV: OFV26-0465

### N° 1 Pcs

Tank1: DHW  
 Material: **Inox AISI 316L (1.4404)**  
 External treat.: **PICKLED**  
 Internal treat.: **PICKLED**  
 Pressure (exerc./test): **6 bar/NOT TESTED**  
 Insulation: **NOT INSULATED**

**NB**  
 THIS TANK WILL BE DELIVERED IN 2 SEPARATE SECTIONS  
 TO BE ASSEMBLED ON SITE

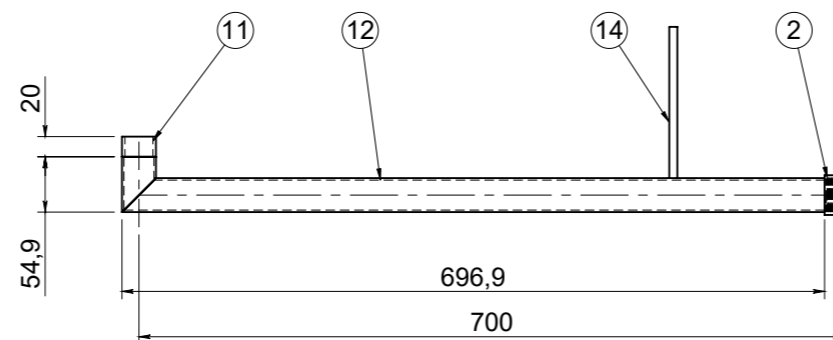
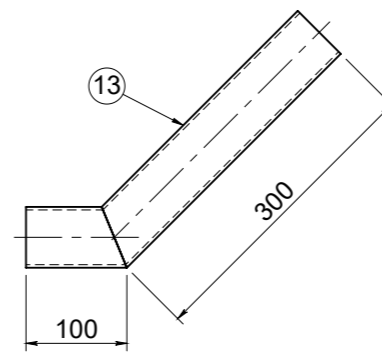
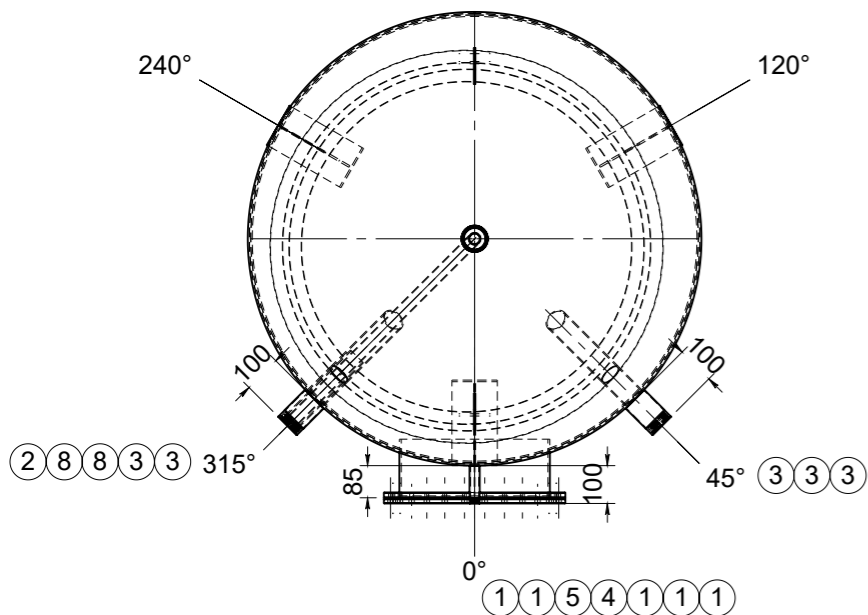
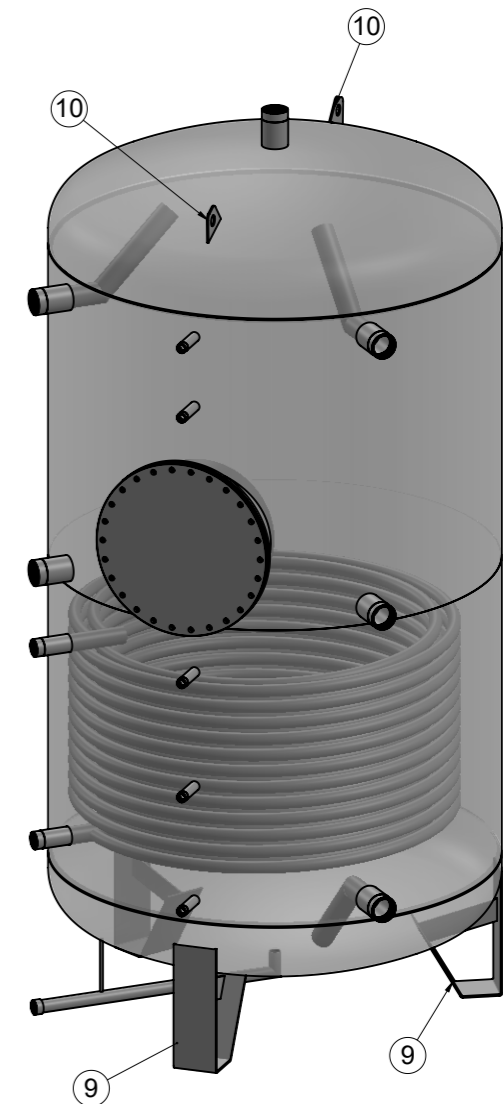

PER CLIENTE

TOLLERANZA QUOTE ± 5MM Dimensions Tolerance ± 5mm	Nome file: TML016710	Nr. Articolo:	
	Stato: <b>In Approv.ne Comm.le</b>	<b>99.03301452-26N</b>	
	Data: 30/03/2026	WP1X SPECIALE 2500 Lt - SEZIONATO NUDO	
	Autore: Giuliano Iodice		
	Pag: 1 di 1	Scala: 1:20	<b>Foglio1</b>
Formato: <b>A3</b>		Material:	Peso:
		Trattamento:	<b>428.02 kg</b>
		Rev: <b>00_c</b> - Creata: -- -- Approvata: GI 30/03/2026	
		EMISSIONE PER ACCETTAZIONE	

