

Customer: ISPAG
 Ref. order: KST300/125150
 Ref. offer: --
 Ref. OFV: OFV26-0363

N° 1 Pcs

Tank1: DHW
 Material: Inox AISI 316L (1.4404)
 External treat.: PICKLED
 Internal treat.: PICKLED
 Pressure (exerc./test): 6/12 bar

Insulation: NOT INSULATED

EFFECTIVE CAPACITY: 1870 Lt

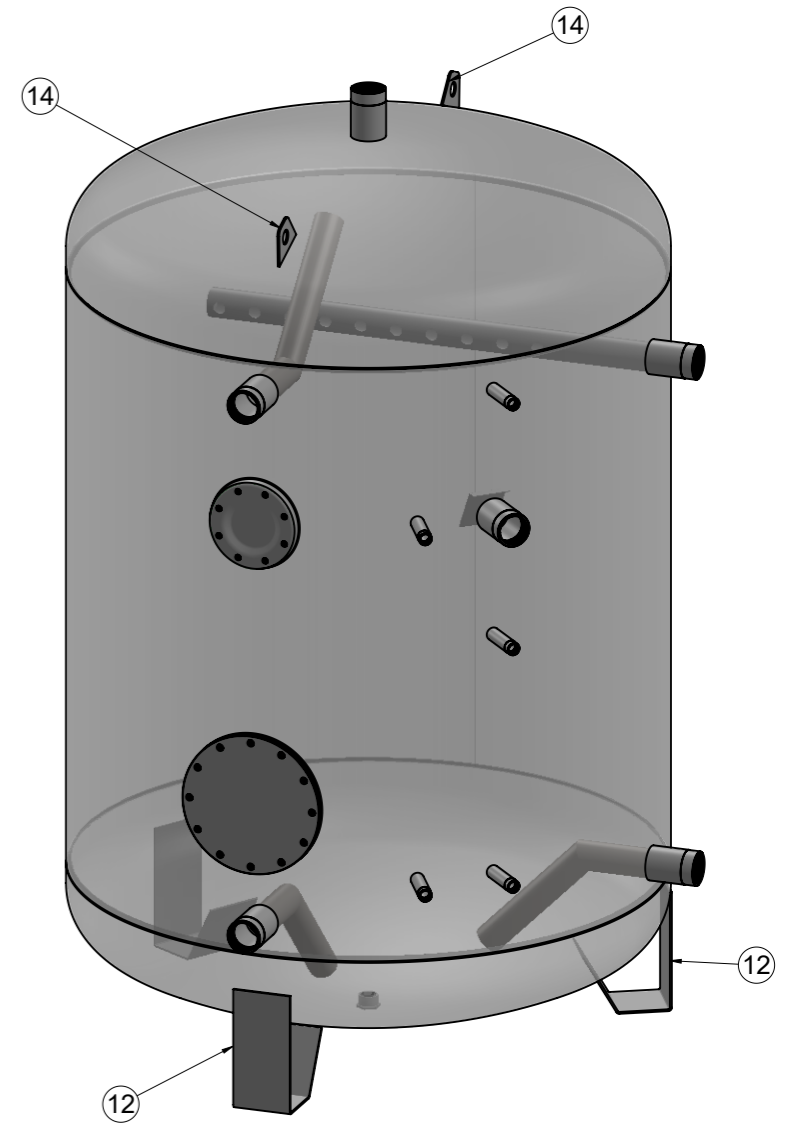
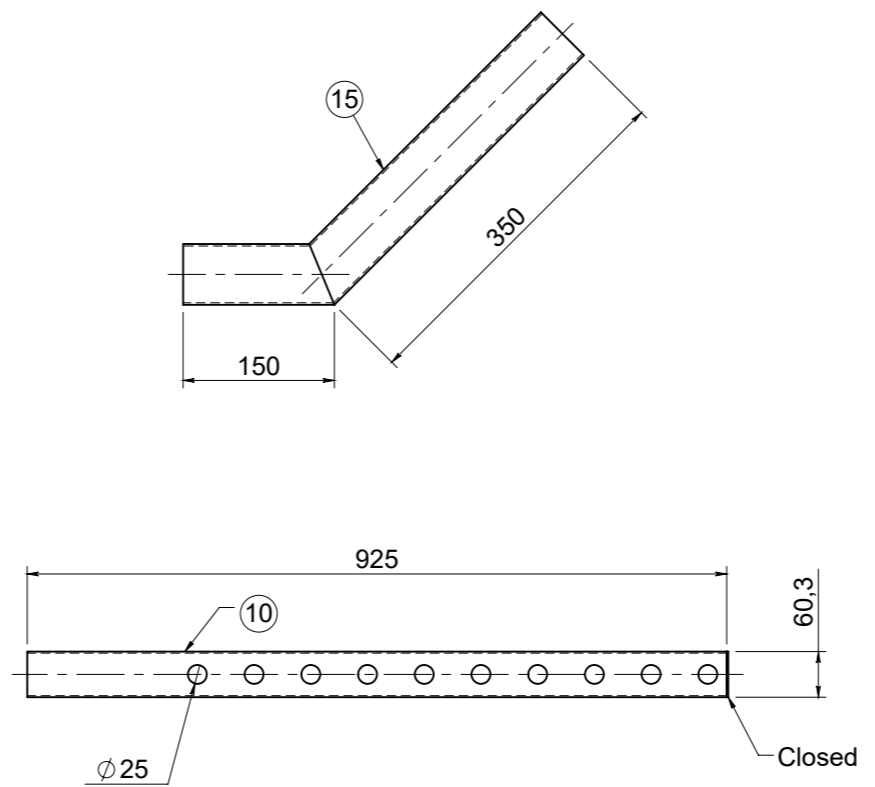

TOLLERANZA QUOTE ± 5MM
 Dimensions Tolerance ±5mm

Bill of Materials: 99.03061228-26N

ID	Description	Code	Notes	Material	UM	Qt	Cut (mm)
1	1/2" L=100	TML000864		Inox AISI 316L (1.4404)	PZ	5	--
2	1" L=20	TML000720		Inox AISI 316L (1.4404)	PZ	1	--
3	2" L=100	TML001095		Inox AISI 316L (1.4404)	PZ	6	--
4	120/180 BLIND	TML002195		Inox AISI 316L (1.4404)	PZ	1	--
5	220/290 BLIND	TML005496		Inox AISI 316L (1.4404)	PZ	1	--
6	120/180 GASKET	TML005559		Sesalit Eco	PZ	1	--
7	220/290 GASKET	TML005556		Sesalit Eco	PZ	1	--
8	120/180 FLANGE	TML001535		Inox AISI 316L (1.4404)	PZ	1	--
9	220/290 FLANGE	TML001536		Inox AISI 316L (1.4404)	PZ	1	--
10	DN50 PIPE L=925 W/2 ROWS D..25	TML013154		Inox AISI 316L (1.4404)	PZ	1	--
11	DEFLECTOR	TML006222		Inox AISI 316L (1.4404)	PZ	1	--
12	D.1200 FOOT	TML005299		Inox AISI 304 (1.4307)	PZ	3	--
13	1" CAP	TML003648		Inox AISI 316L (1.4404)	PZ	1	--
14	LIFTING POINT	TML005372		Inox AISI 304 (1.4307)	PZ	2	--
15	DN50 SPARGE PIPE	TML010874		Inox AISI 316L (1.4404)	MT	0.5	1 x 500
16	DN50 SPARGE PIPE	TML010874		Inox AISI 316L (1.4404)	MT	0.9	2 x 450

PER CLIENTE

Nome file: TML016471	Nr. Articolo: 99.03061228-26N
Stato: In Approv.ne Comm.le	ATX SPECIALE 2000 Lt NUDO
Data: 06/03/2026	
Autore: Giuliano Iodice	
Pag: 1 di 1	Scala: 1:15
Formato: A3	Foglio1
Materiale:	Peso: 218.04 kg
Trattamento:	
Rev: 00_c - Crea: -- -- -- Approvata: GI 06/03/2026	
EMISSIONE PER ACCETTAZIONE	