

WITHOUT INSULATION

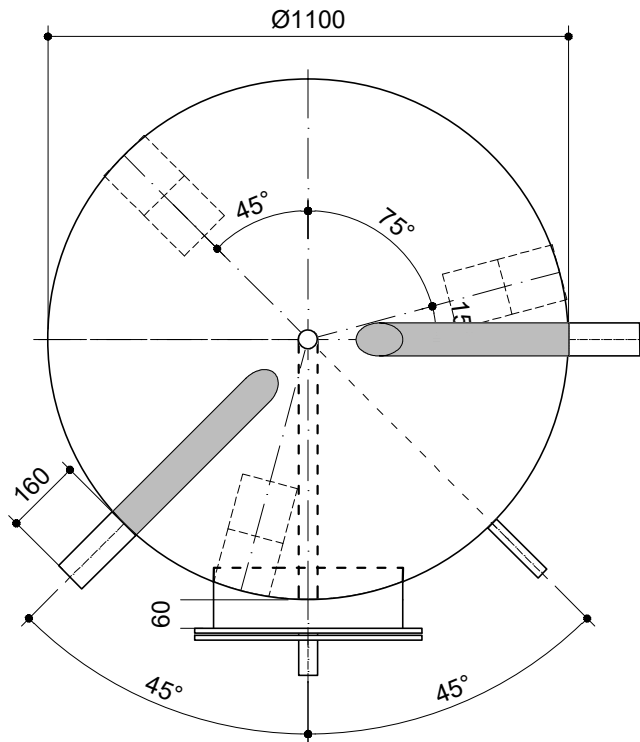

code: **99.02191017-26N**

N° 1 Pcs.
ATX 1300 N SPECIAL

CUSTOMER: ISPAG
Ref. ORDER: KST300/124913
OF: 18/02/2026

MATERIAL: Inox Aisi 316L
EXTERNAL TREAT.: Pickling
INTERNAL TREAT.: Pickling
WORKING PRESSURE: 6 bar
TEST PRESSURE: 9 bar
NOT TESTED

R0 - 19/02/2026 - PRIMA EMISSIONE
R1 - 26/03/2026 - AGGIORNAMENTO DISEGNO

MATERIAL:	WEIGHT:	WORKING PRESSURE / TEST:	
Inox Aisi 316L	≈ 225 Kg	6 bar / 9 bar	
EXTERNAL TREATMENT	INTERNAL TREATMENT:	V	F
Pickling	Pickling		



DESIGNED BY:	APPROVED:	DATE:
GIOVANNINI	Ing. Buccigrossi	19/02/2026
CUSTOMER:	ORDER N°:	
ISPAG		
DESCRIPTION :	DRAWING CODE.	
	--	

The TML reserves the right to make constructional improvements of the product or changes without notice. This drawing cannot be copied, reproduced or shown to third parties without our approval.